



# *COMPLETE*

DATIEN CUTTING SYSTEM (U TYPE)

# PAPER UNLOADER MACHINE

DATIEN Paper Cutting System with UNLOADER is to give ideally smooth workflows for Printing company, Silk-screen printers, Label producers, Bookbinderies and Converters.

Finished Stock can be delivered to Printing Press directly or finishing or packing from UNLOADER, to save one hand-pass time, to protect workers for health and safe.

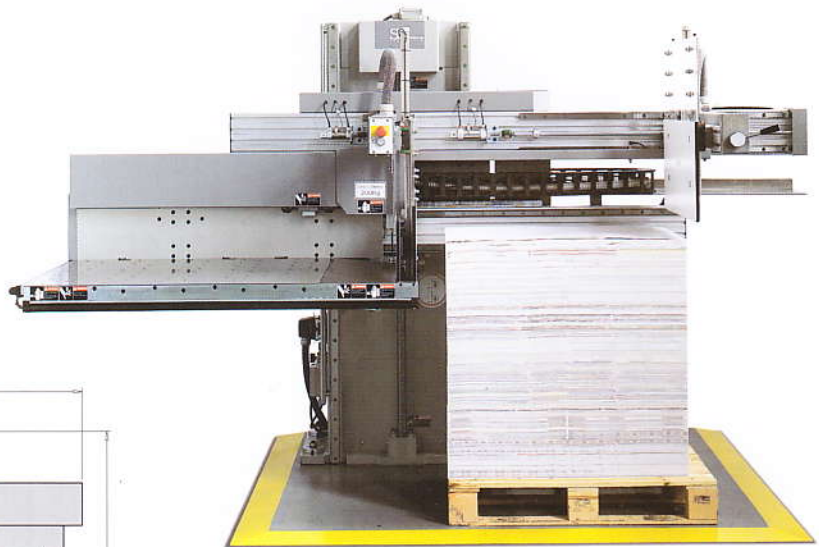

■ DUL-125L

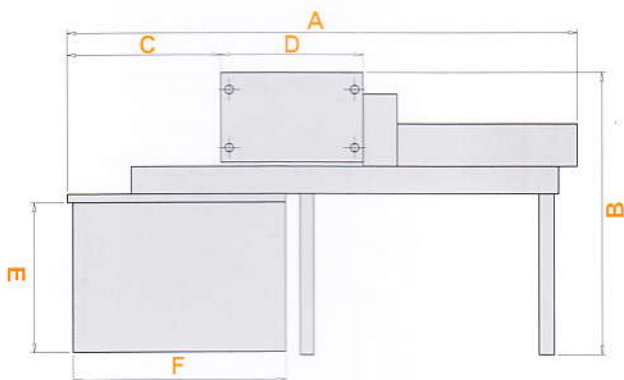

## MACHINE SPECIFICATION

MODEL	DUL-125L	DUL-125R
A (cm/inch)	300(118 1/8)	300(118 1/8)
B (cm/inch)	165(64 15/16)	165(64 15/16)
C (cm/inch)	90(35 1/2)	90(35 1/2)
D (cm/inch)	84(33)	84(33)
E (cm/inch)	87(34 1/2)	87(34 1/2)
F (cm/inch)	125(49 1/4)	125(49 1/4)

1. Sheet size(max) cm/inch 80x125(31 1/2x49 1/4)  
(min) cm/inch 80x40 (31 1/2x15 3/4)
2. Height of ream,max cm/inch 16.5(6 1/2)
3. Stack Height,min cm/inch 10(3 15/16)  
max cm/inch 130(51 3/16)
4. Carrying capacity max,Kg/lbs 200(440)
5. Weight,net 1150 Kg
6. Power 2.3Kw(3.1Hp)

MACHINE Height:188cm/74inch

L:Placed On Cutter Left

R:Placed On Cutter Right

\* Specification could be changed for improvement without prior notice.

# COMPLETE



**DATIEN CUTTING SYSTEM (U TYPE)**

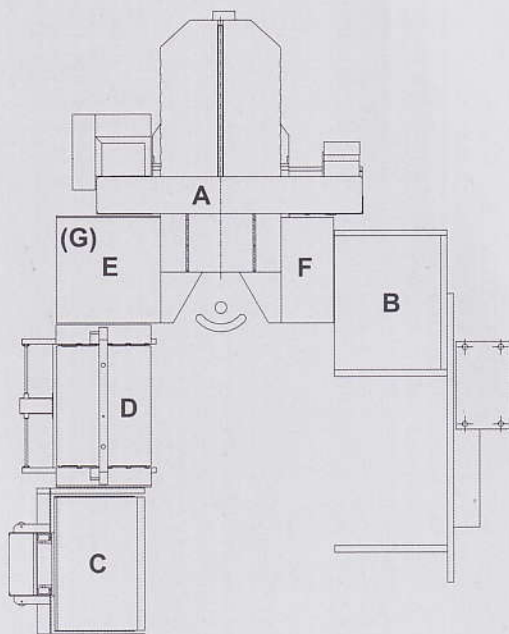

- A : PAPER CUTTING MACHINE,CT-115ECE
- B : PAPER UNLOADER MACHINE,DUL-125L
- C : LIFTER MACHINE,DL-120
- D : PAPER JOGGING MACHINE,DJ-115A
- E : AIR TABLE 100cmx100cm
- F : AIR TABLE 50cmx100cm
- G : BLOWER

**DATIEN CUTTING SYSTEM (L TYPE)**

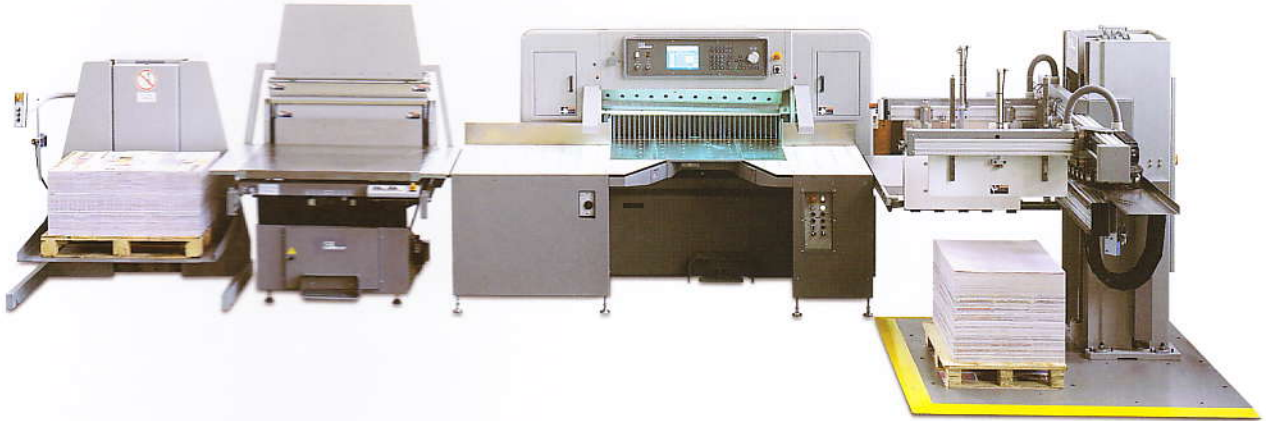

**DATIEN CUTTING SYSTEM (— TYPE)**

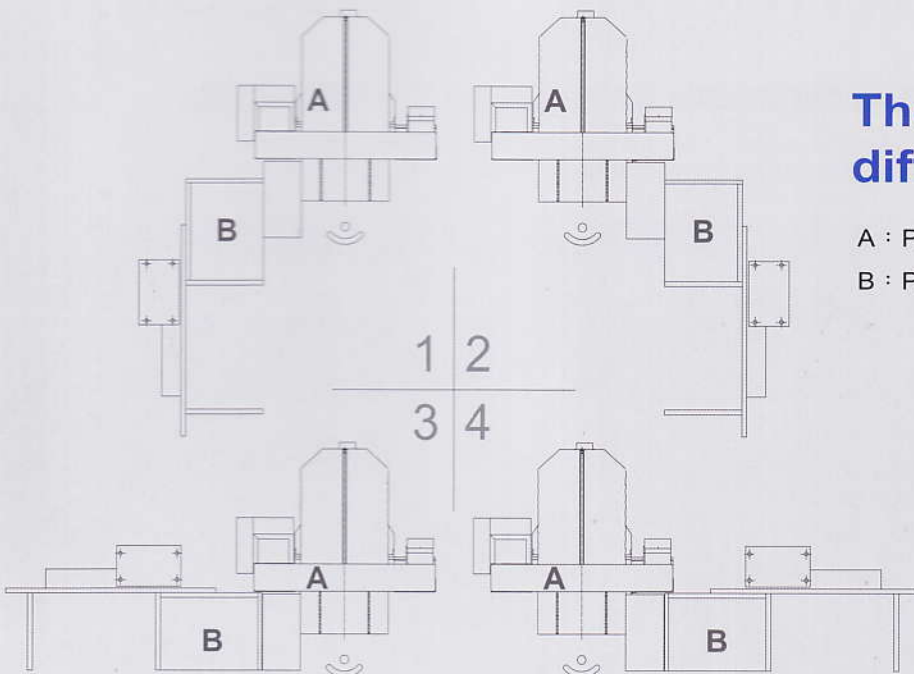

**There are 4 kinds different system**

A : PAPER CUTTING MACHINE

B : PAPER UNLOADER MACHINE